

- 1.0 GENERAL NOTES
 1.1 ALL IMPERIAL DIMENSIONS ARE IN BRACKETS [X.XX]
 1.2 MARK PART WITH IDENTIFICATION NUMBER
 2.0 DESIGN NOTES
 3.0 MANUFACTURING/SPECIAL REQUIREMENTS
 3.1 TIGHTEN ALL BOLTS SECURING FLAT PLATES BY THE TURN-OF-NUT METHOD. TIGHTEN ALL U-BOLTS USING TURN-OF-NUT METHOD WITH ATTENTION TO LEAVE EQUAL DISTANCE AND EQUAL FORCE ON EACH LEG OF THE U-BOLT.
 4.0 TEST
 5.0 PACKAGING
 5.1 PACKAGING SHALL MEET COMMSCOPE REQUIREMENTS PER DOCUMENT IS-PL-3005
 5.2 PRINTED DOCUMENT TO BE PLACED INSIDE POLYBAG AND THEN IN SHIPPING CONTAINER
 5.3 EXTRA HARDWARE MAYBE SUPPLIED, BAGGED AND SHIPPED

REVISIONS			
REV.	DESCRIPTION	DATE	APPROVED
A	INITIAL RELEASE	JL1183 16MAR23	JAHAINES 40168212CMO

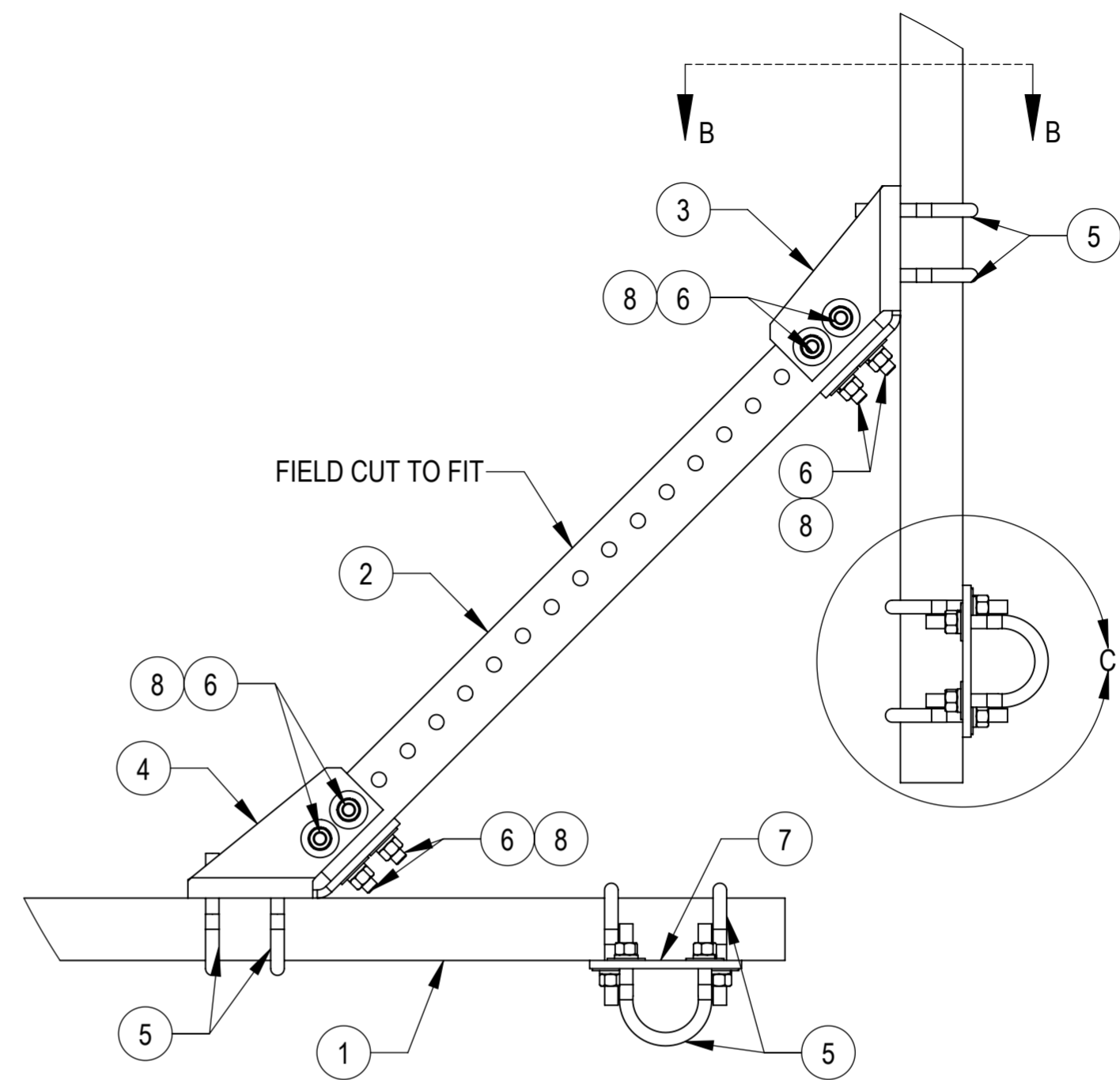

FIT $\phi 60.3[2.375]$ O.D. AND $\phi 73.0[2.875]$ O.D.
 ANTENNA MOUNT PIPE
 (NOT INCLUDED IN THIS KIT)

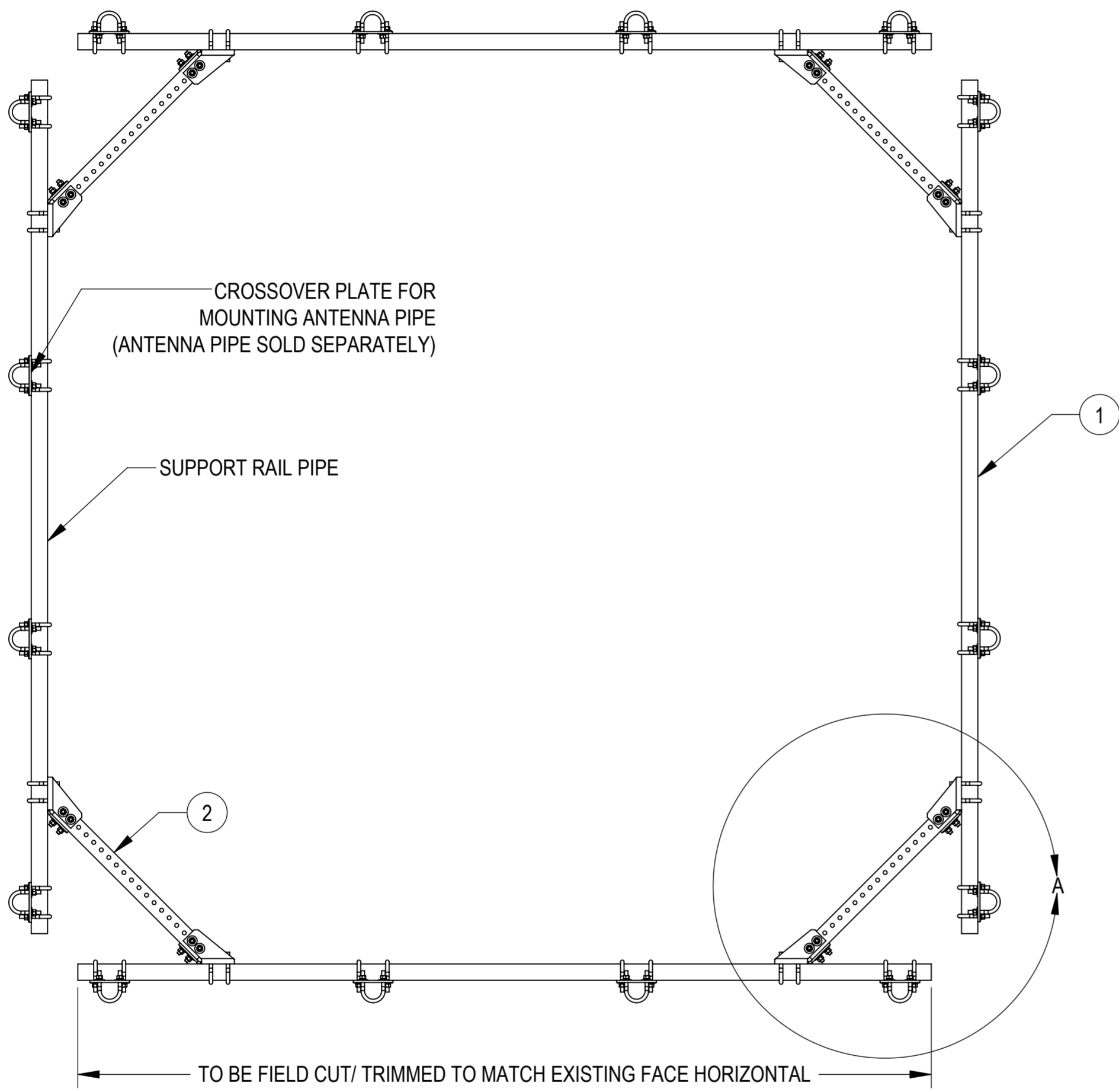
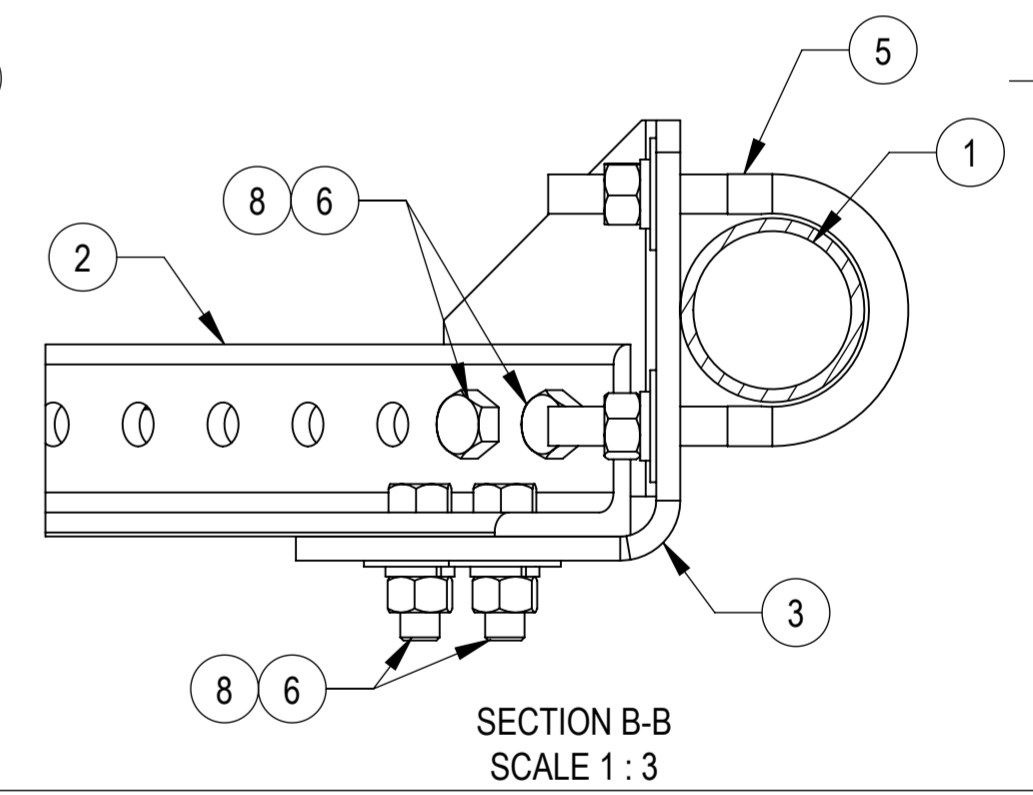
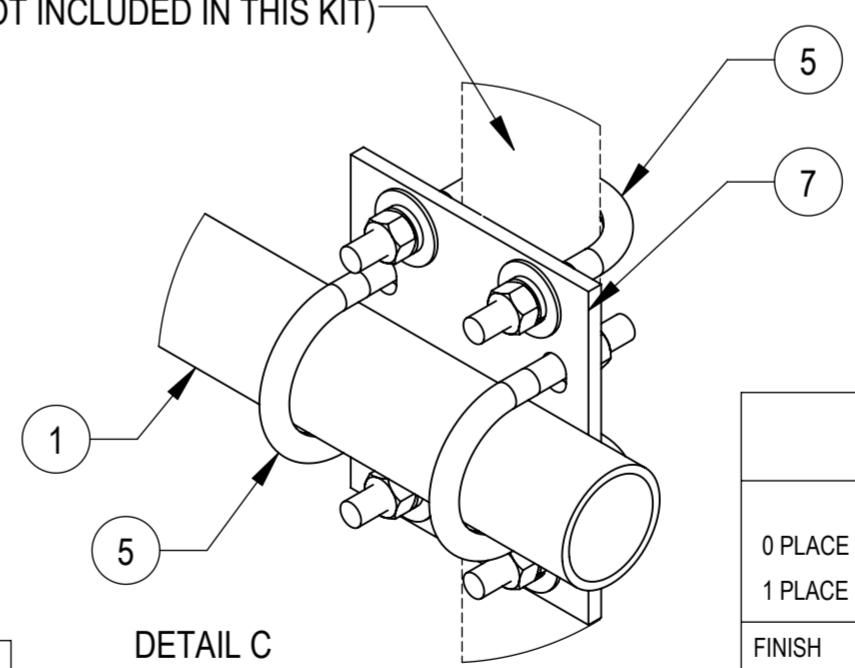

COMPONENT PART NUMBERS PROVIDED FOR ASSEMBLY PURPOSES;
 INDIVIDUAL COMPONENTS MAY BE SHIPPED AS PARTS WITHIN AN INCLUDED KIT.

ITEM NO.	PART NO.	DESCRIPTION	QTY.	NOTE NO.
1	MT-546-150	PIPE, 2.875"OD X 150"	4	
2	PLK2-F1-30	ANGLE, BRACE; 36.0 LG	4	
3	CBP4-L	CORNER BENT PLATE BRACKET, LH	4	
4	CBP4-R	CORNER BENT PLATE BRACKET, RH	4	
5	GUB-53050	5/8" X 3" X 5" GALV U-BOLT KIT	80	INCLUDES U-BOLT, FLAT WASHERS, LOCK WASHERS AND NUTS
6	GB-0520A	5/8" X 2" GALV BOLT KIT (A325)	32	INCLUDED BOLT, LOCK WASHER AND NUT
7	MTC4104-0030	PLATE, CROSSOVER; 2.375 TO 2.875 OD PIPE	16	
8	GWF-05	5/8" GALV FLAT WASHER, 1.7OD	32	

COMMSCOPE, INC. OF NORTH CAROLINA

TOLERANCES
 0 PLACE X[.X] ± 6[0.25] 2 PLACE .XX[.XXX] ± 1.50[0.06]
 1 PLACE .X[.XX] ± 3.0[0.12] ANGLES ± 2°

SAP MATERIAL MASTER
MUK-PLK1Q

FINISH			MATERIAL		
CE	JL1183	16MAR23	4-SIDED SUPPORT RAIL KIT SCALE 1:10 DOCUMENT NO. MUK-PLK1Q		
RW	JL1183	03/21/2023			
AD	YW1045	03/23/2023			
RE	YMENG	03/24/2023			
ECN 40168212CMO					

SIZE	Auth Group	INSL	MODEL	REVISION	VERSION	STATUS	REVISION	VERSION	STATUS	REVISION	SHEET
A2				A	00	RE	A	00	RE	A	1 OF 1

UNLESS OTHERWISE SPECIFIED
 DIMENSIONS ARE IN MILLIMETERS
 INTERPRET PER ANSI Y 14.5M-1994

© 2023 CommScope, Inc. Confidential