

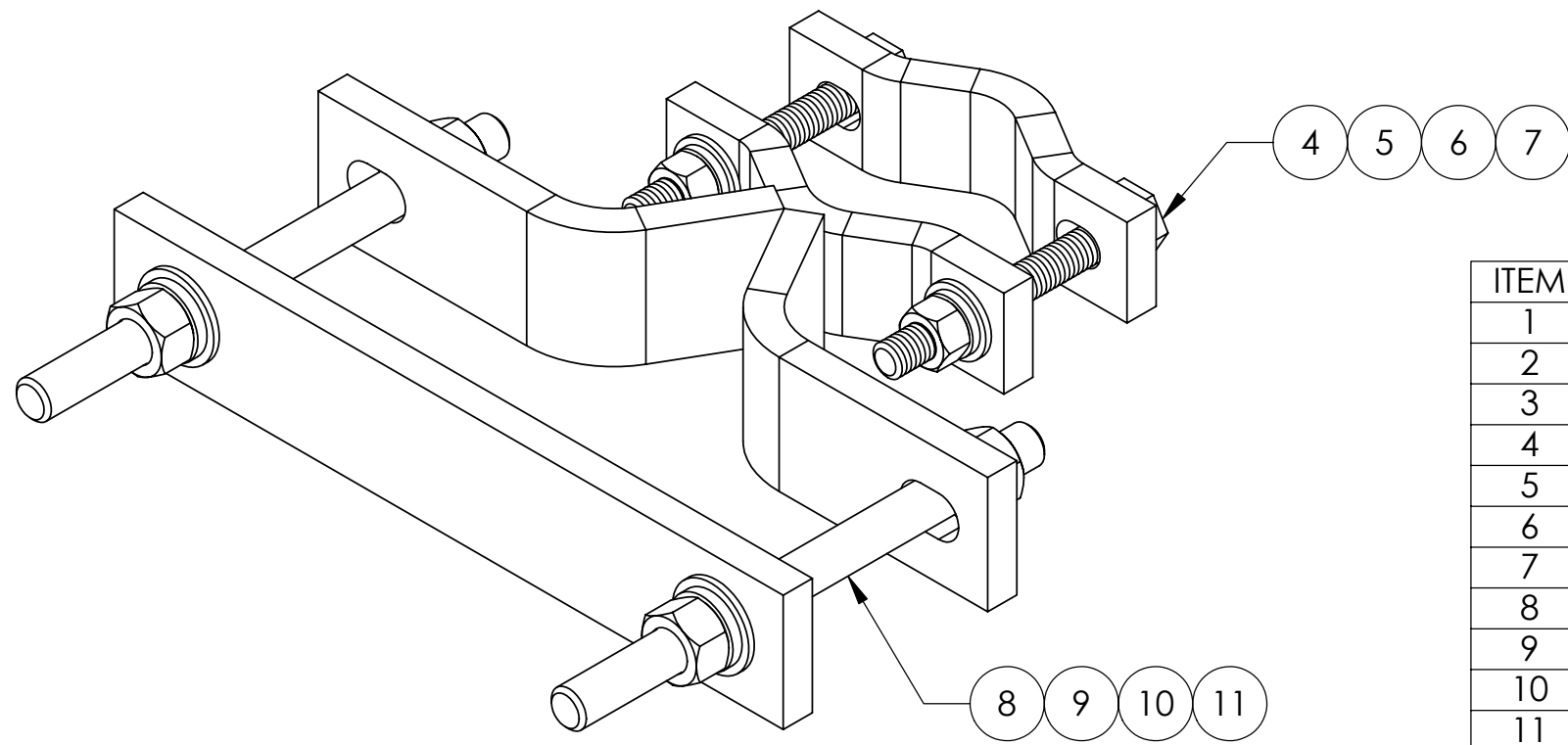

REVISIONS				
REV.	ZONE	DESCRIPTION	BY	DATE
A		INITIAL RELEASE	JTS	03/28/01
B		REVERSED HARDWARE FOR PROPER ASSEMBLY	ACG	09/29/05

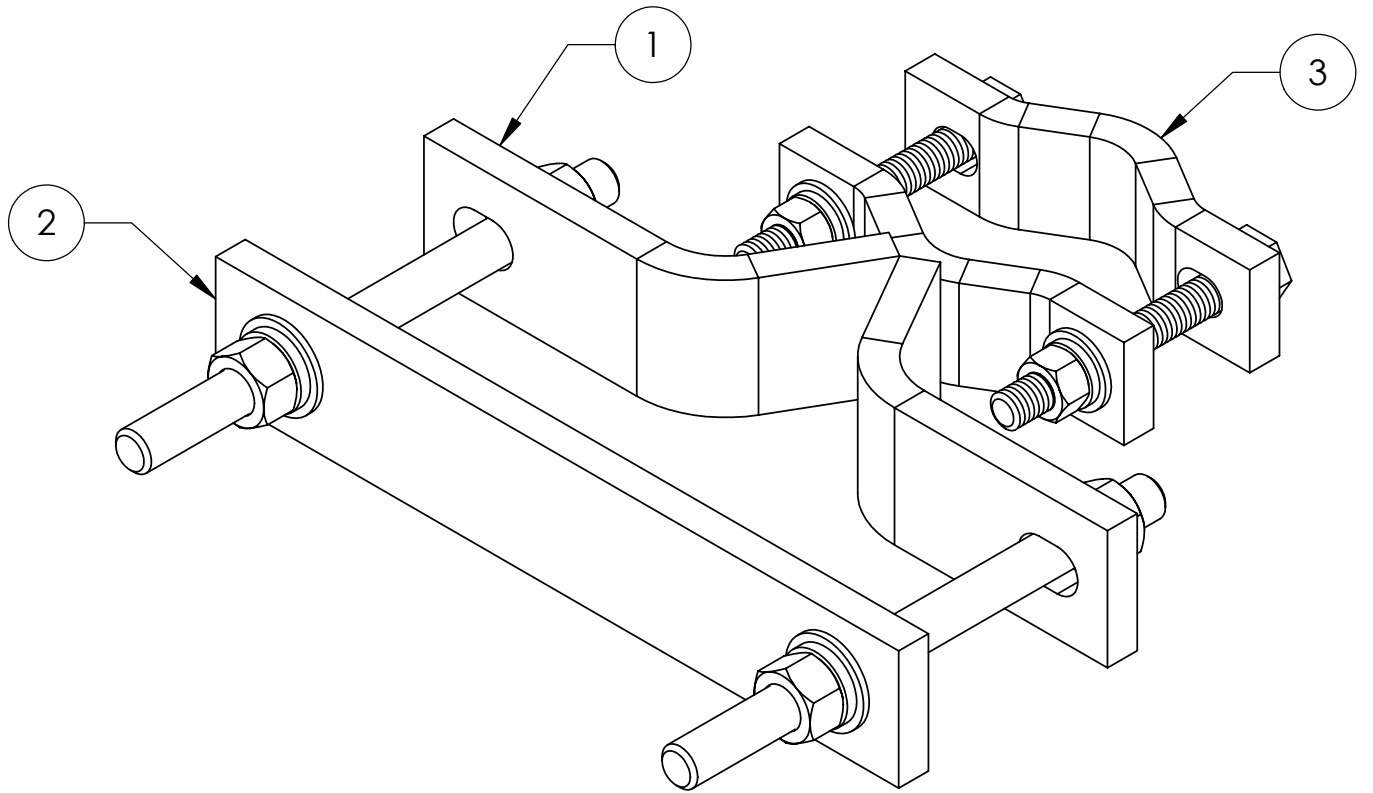

ITEM	PART NO.	DESCRIPTION	QTY.	WEIGHT
1	M60SA	MEDIUM 60° TO DISH (ROUND) ADAPTER	2	4.77 LBS
2	MCF	2" X 11.5" X .5" STRAIGHT BAR ADAPTOR	2	3.08 LBS
3	SC-P10	SMALL DISH CLAMP HALF	2	1.20 LBS
4	12-04-FTB	1/2" x 4" FULL THREAD GALV. BOLT	4	0.23 LBS
5	GN04A	1/2" GALV HEX NUT (A325)	4	0.08 LBS
6	GWL-04	1/2" GALV LOCK WASHER	4	0.01 LBS
7	GWF04A	1/2" GALV FLAT WASHER (A325)	8	0.02 LBS
8	MT-381-8	5/8" X 8" GALV THREADED ROD	4	0.64 LBS
9	GN05A	5/8" GALV HEX NUT (A325)	8	0.08 LBS
10	GWL-05	5/8" GALV LOCK WASHER	8	0.01 LBS
11	GWF05A	5/8" GALV FLAT WASHER (A325)	8	0.03 LBS

NOTES:
 1. ALL METRIC DIMENSIONS ARE IN BRACKETS.

<small>These drawings and specifications are the proprietary property of ANDREW CORPORATION and may be used only for the specific purpose authorized in writing by Andrew Corporation.</small> <small>ALL DIMENSIONS ARE IN INCHES U.O.S.</small> <small>TOLERANCES UNLESS OTHERWISE SPECIFIED:</small> .X = ± .06 ANGLES ±2° .XX = ± .03 FRACTIONS ±1/32 .XXX = ± .010 <small>REMOVE BURRS AND BREAK EDGES .005</small>	<small>DRAWN BY:</small> ACG	<small>SHEET:</small> 1 of 1	<small>PART NUMBER:</small> AD-P60-SCP	
	<small>CHECKED BY:</small> TP	<small>SCALE:</small> NTS	<small>DESCRIPTION:</small> ADAPTER CLAMP SET, 60° ANGLE LEG	
	<small>DATE:</small> 09/29/05	<small>MATERIAL:</small> A36, A53	<small>DRAWING TYPE:</small> ASSEMBLY DRAWING	
	<small>REVISION:</small> B	<small>FINISH:</small> GALV A123	 ORLAND PARK, IL. 60462 U.S.A.	
<small>DO NOT SCALE THIS PRINT</small>	<small>WEIGHT:</small> 89.56 LBS			